

SINGLE-DISC SANDING MACHINE SINGLE



English / Englisch

Spare Parts

for the single-disc sanding machine

SINGLE

Lägler
www.laegler.com

Copyright © Eugen Lägler GmbH, 2019 – All rights reserved. Subject to changes.



00.850.20.802 01.06.2019

SERIAL NUMBER OF SINGLE

ATTENTION!

In order to receive the correct spare parts from us, please specify in inquiries and spare part orders always the serial numbers of your machines!

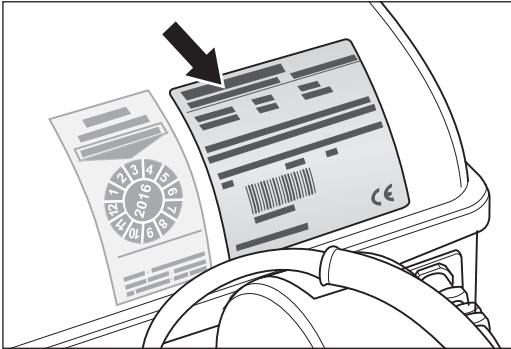

Fig. 1 Type plate on motor cover.

The type plate of SINGLE is located on the motor cover (fig. 1). The following technical data are specified on the type plate (fig. 2):

- 1 Manufacturer
- 2 **Serial number of machine (Mach.-No.)**
- 3 Year of manufacture (Year)
- 4 Machine name (Type)
- 5 Required mains voltage in volt (V)
- 6 Current consumption in ampere (A)
- 7 Motor frequency in CPS (Hz)
- 8 Motor power in kilowatt (KW)
- 9 Motor speed in 1/min (Rpm)
- 10 Weight of machine in kilogram (Weight)
- 11 Insulation class (Insul. Cl.)
- 12 Protection class (Prot. Cl.)
- 13 Type of current
- 14 Country of manufacture

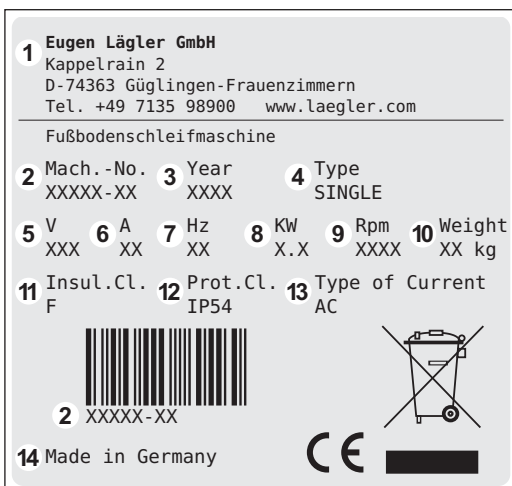
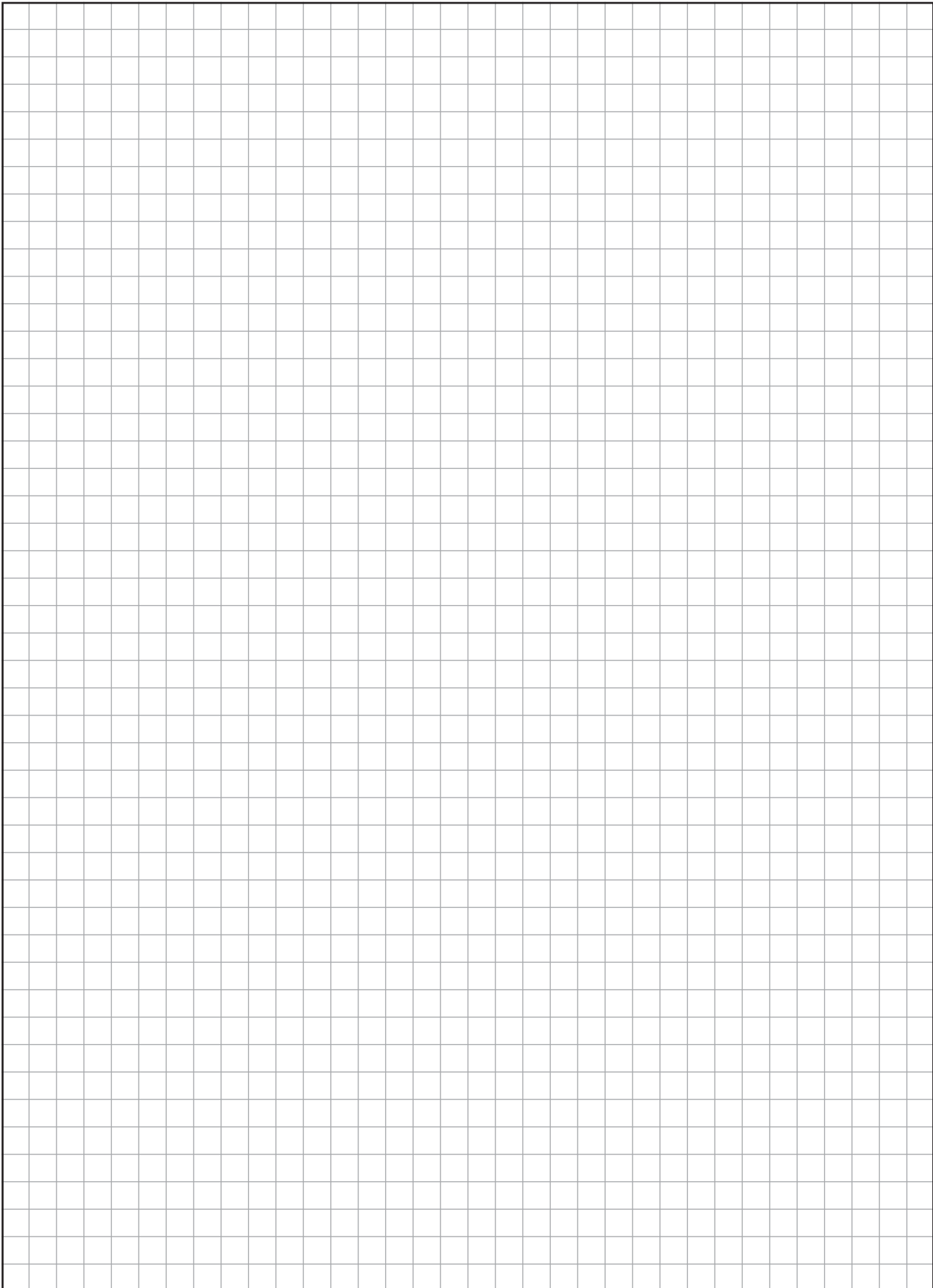
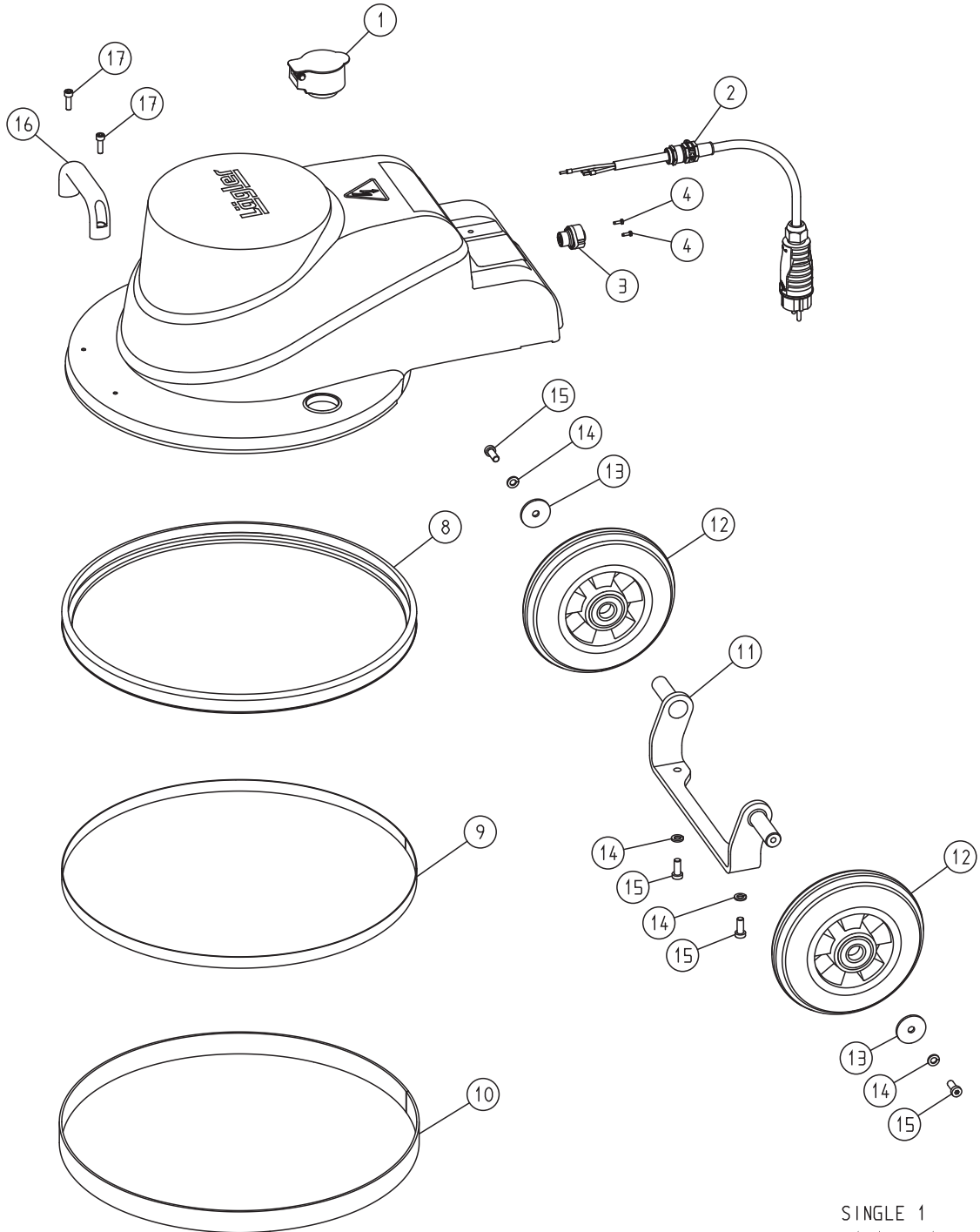

Fig. 2 Data on type plate.



SPARE PARTS SINGLE

ATTENTION: Please specify in inquiries and spare part orders always the serial numbers of your machines!



SINGLE 1
01.12.2018

SPARE PARTS SINGLE

Item	Part number	Description
1	850.01.80.200	Dust extraction socket
2	000.65.43.252	Motor cable 3 x 2.5 mm ²
3	000.65.71.040	Integrated socket
4	7500.1003.010	Screw
8	850.01.02.105	Buffer
9	850.01.40.100	Velcro
10	850.01.51.100	Fluffy sealing strip
11	850.05.10.100	Wheel holder
12	850.05.19.105	Wheel (from year of manufacture 2019)
	850.05.09.105	Wheel (up to year of manufacture 2018)
	0125.1012.000	Washer (for wheel up to year of manufacture 2018)
	0471.0012.000	Circlip (for wheel up to year of manufacture 2018)
13	000.10.10.085	Washer
14	0127.1008.000	Spring washer
15	7984.1008.020	Screw
16	000.20.10.121	Handle
17	0912.1006.020	Screw



ATTENTION: Please specify in inquiries and spare part orders always the serial numbers of your machines!

SPARE PARTS SINGLE

ATTENTION: Please specify in inquiries and spare part orders always the serial numbers of your machines!

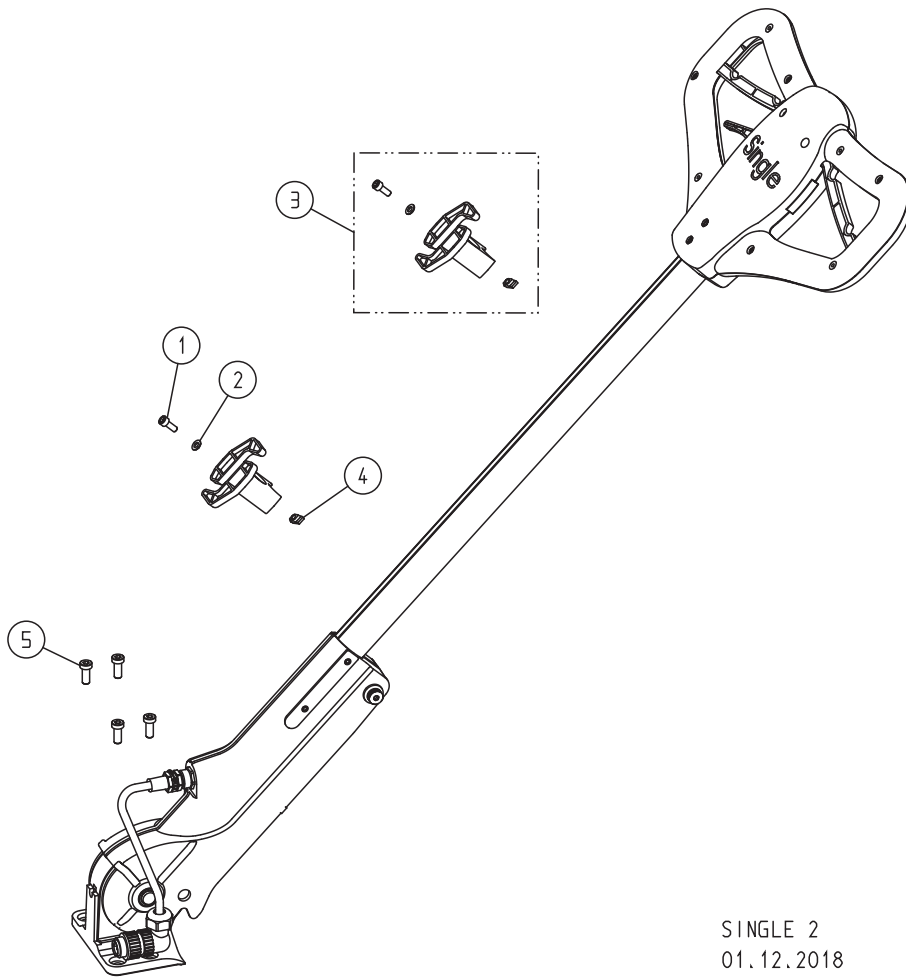

SINGLE 2
01.12.2018

SPARE PARTS SINGLE

Item	Part number	Description
	850.20.00.200	Handle SINGLE, complete
1	0912.1006.016	Screw
2	0125.1006.000	Washer
3	850.20.26.100	Cable holder complete
4	850.20.29.100	Sliding block
5	7984.1008.020	Screw

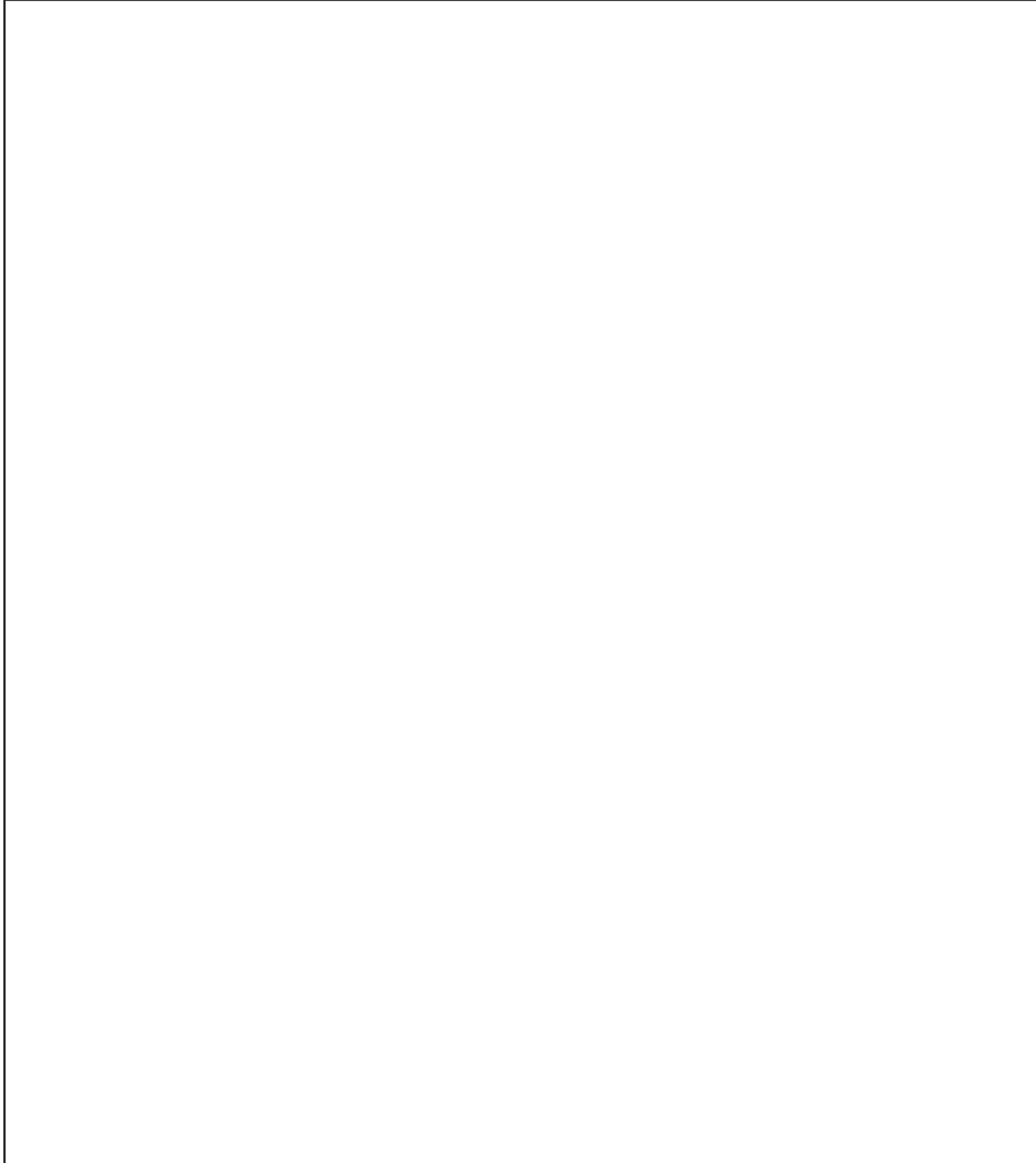

ATTENTION: Please specify in inquiries and spare part orders always the serial numbers of your machines!

SPARE PARTS SINGLE

ATTENTION: Please specify in inquiries and spare part orders always the serial numbers of your machines!

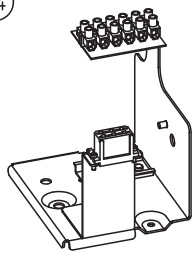
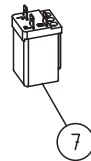
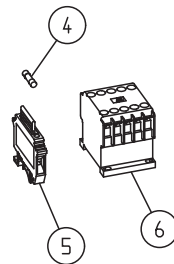
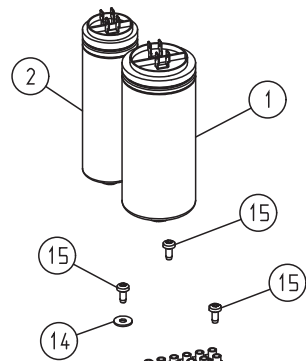
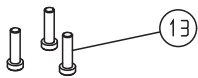
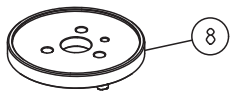
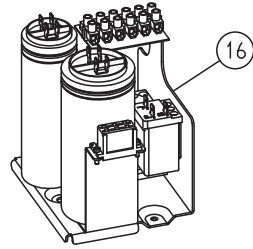
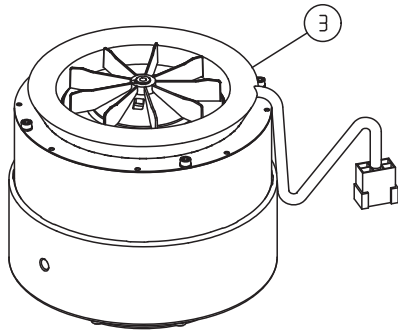

SINGLE 3
01.01.2013

SPARE PARTS SINGLE

Item	Part number	Description
1	000.65.10.041	Running capacitor 40 µF
2	000.65.10.061	Starting capacitor 60 µF
3	850.65.00.200	Motor, 230 V / 50 CPS / 1.2 kW
4	000.65.80.061	Fuse, 6.3 A
5	000.65.82.010	Fuse holder
6	000.65.20.012	Contacto
7	000.65.20.230	Relay
8	850.64.06.100	Adapter mounting
9	850.64.07.205	Shock absorber
10	850.64.08.100	Plate mounting
11	1481.0006.032	Spring type straight pin
12	6797.1008.000	Washer
13	7984.1008.030	Screw
14	9021.1005.000	Washer
15	7500.1005.012	Screw
16	850.65.80.100	Control electric system complete, 230 V / 50 CPS



ATTENTION: Please specify in inquiries and spare part orders always the serial numbers of your machines!

SPARE PARTS SINGLE

ATTENTION: Please specify in inquiries and spare part orders always the serial numbers of your machines!

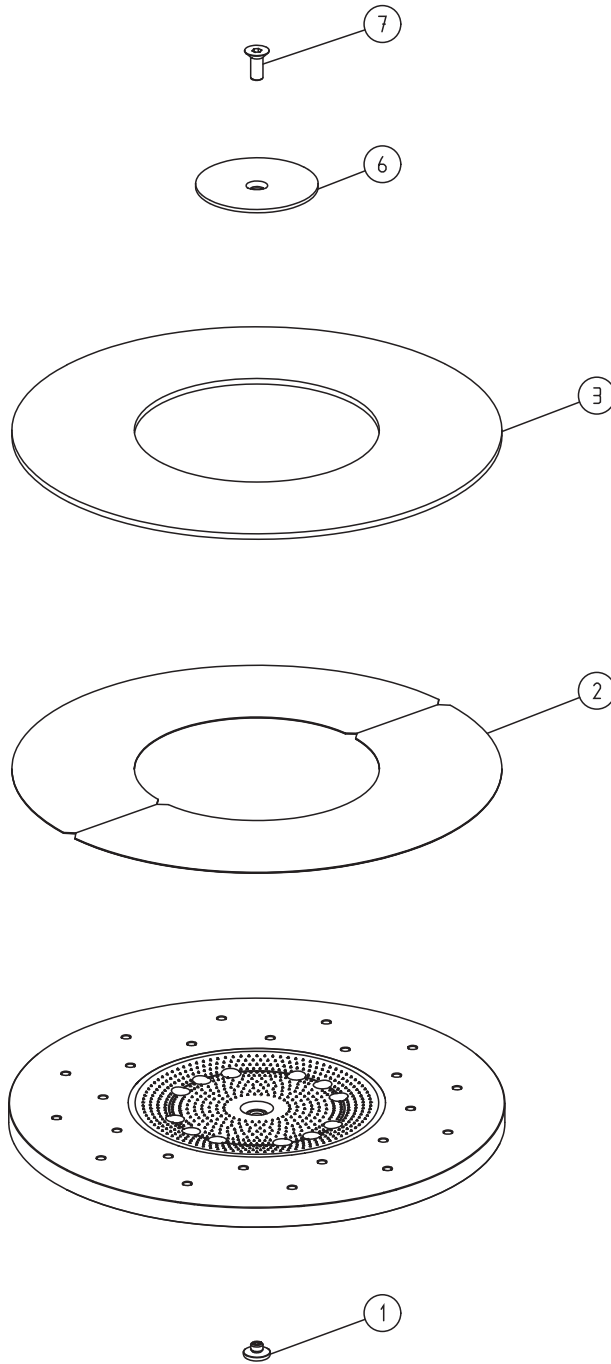

SINGLE 4
01.01.2010

SPARE PARTS SINGLE

Item	Part number	Description
	850.02.10.100	Sanding plate SINGLE complete, for double-faced sanding discs, velcro sanding discs and pads
1	850.02.06.200	Centering dome
2	850.02.11.100	Velcro coating, for pad and Velcro sanding disc (two parts necessary)
3	850.02.13.105	Velcro ring flexible
6	850.02.05.100	Paper tensioning disc
7	7991.1010.725	Screw, left-handed thread

--	--	--

ATTENTION: Please specify in inquiries and spare part orders always the serial numbers of your machines!

SPARE PARTS SINGLE

ATTENTION: Please specify in inquiries and spare part orders always the serial numbers of your machines!

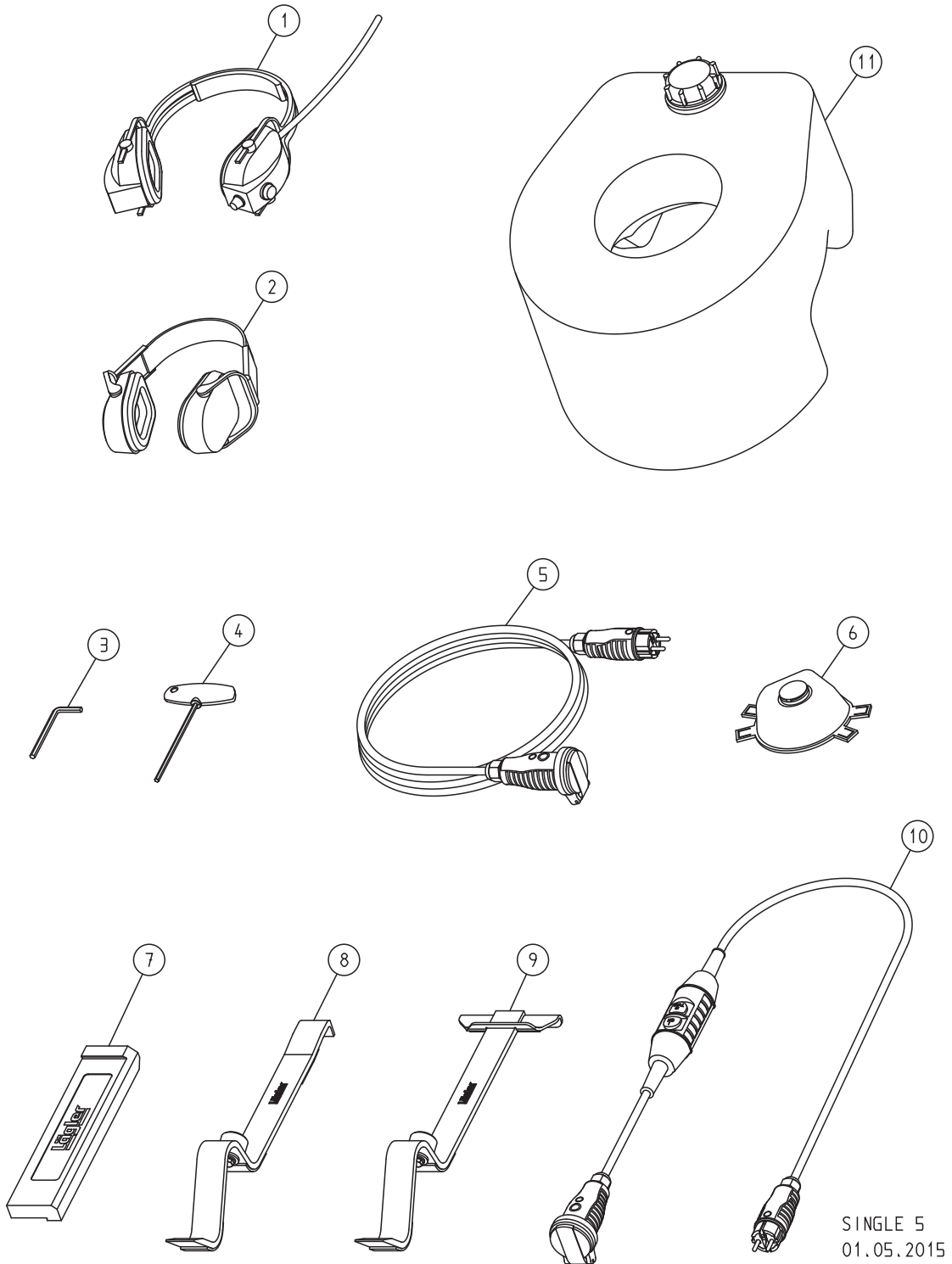

SINGLE 5
01.05.2015

SPARE PARTS SINGLE

Item	Part number	Description
1	000.01.10.011	Foldable earmuff type MUSIMUFF with FM radio
2	000.01.10.021	Foldable earmuff type POCKET
3	000.93.11.061	Hexagonal socket screw wrench 6 mm
4	000.93.12.052	Hexagonal socket screw wrench 5 x 150 mm
5	000.65.53.251	Extension cable 3 x 2.5 mm ² , 10 m long
6	000.01.20.010	Respiratory protection mask P3
7	701.10.00.100	Impact tool
8	702.00.00.200	Parquet layer tool ZUGEISEN, small
9	703.00.00.200	Parquet layer tool ZUGEISEN, broad
10	000.01.65.020	Safety switch PRCD-S (for German mains supply)
11	850.80.10.105	Additional weight SINGLE

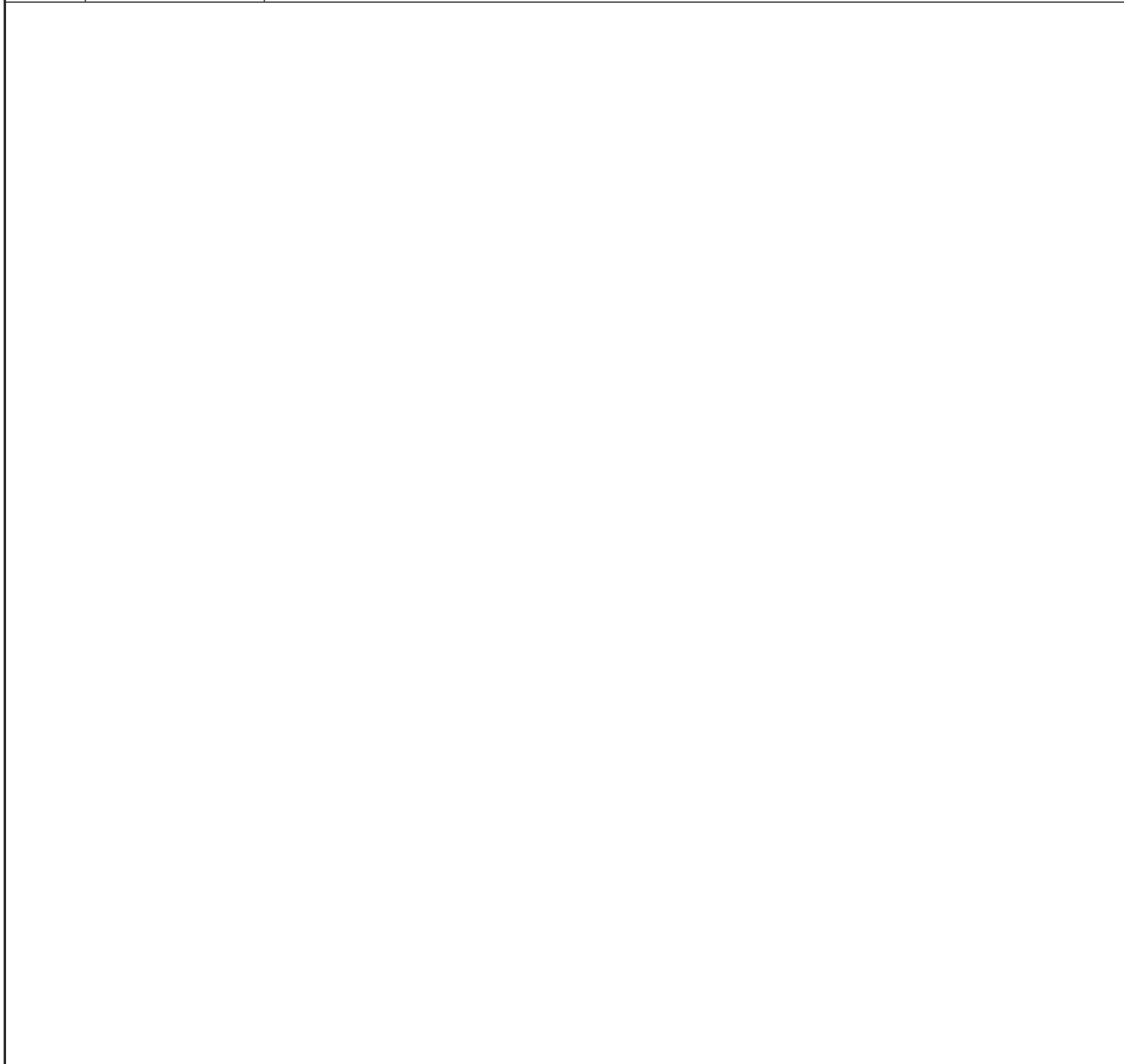

ATTENTION: Please specify in inquiries and spare part orders always the serial numbers of your machines!

SPARE PARTS SINGLE

ATTENTION: Please specify in inquiries and spare part orders always the serial numbers of your machines!

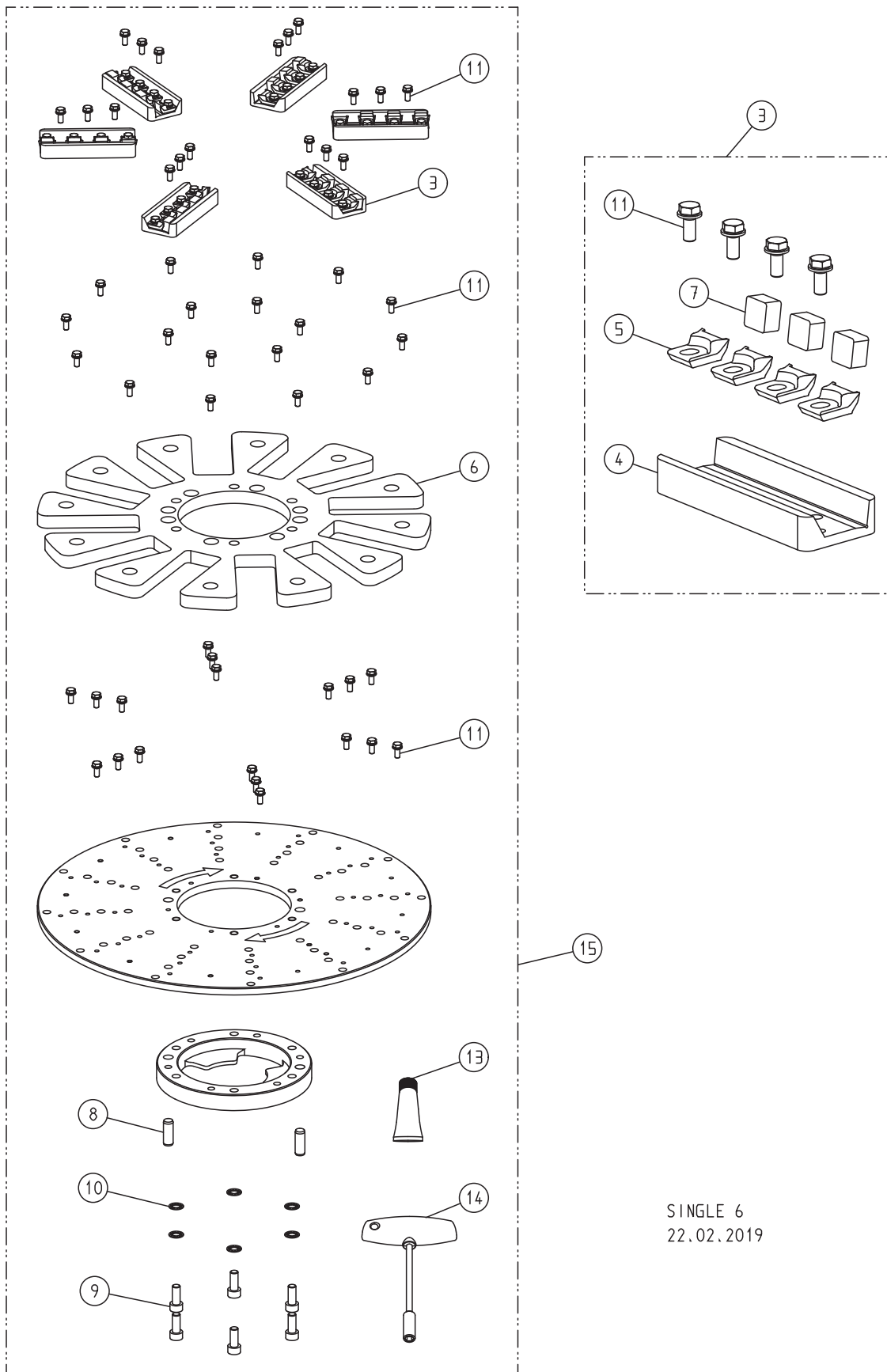

SINGLE 6
22.02.2019

SPARE PARTS SINGLE

Item	Part number	Description
3	850.02.43.100	Cutter holder, complete
4	850.02.45.100	Cutter holder
5	850.02.47.200	Clamping block
6	850.02.49.100	Additional weight for milling disc SINGLE
7	000.10.21.101	Ceramic indexable insert, SINGLE (10 pieces per box)
8	7979.0010.028	Parallel pin
9	0912.1008.020	Screw
10	6797.1008.000	Washer
11	6902.0305.012	Screw
13	00.000.32.501	Copper paste
14	000.93.13.052	Hexagonal socket screw wrench 8 x 125 mm
15	850.02.40.100	Milling disc SINGLE, complete

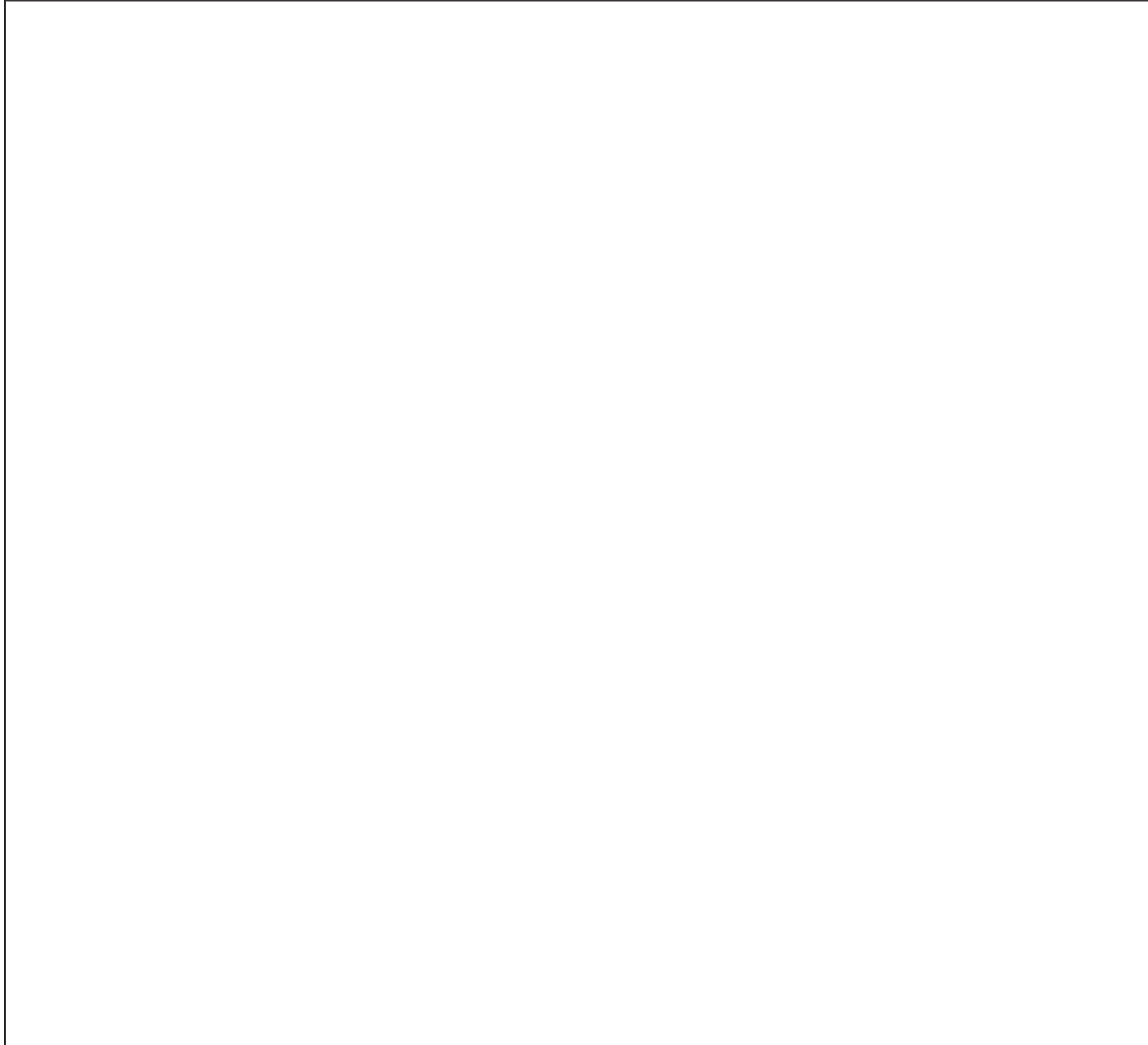

ATTENTION: Please specify in inquiries and spare part orders always the serial numbers of your machines!

SPARE PARTS SINGLE

ATTENTION: Please specify in inquiries and spare part orders always the serial numbers of your machines!

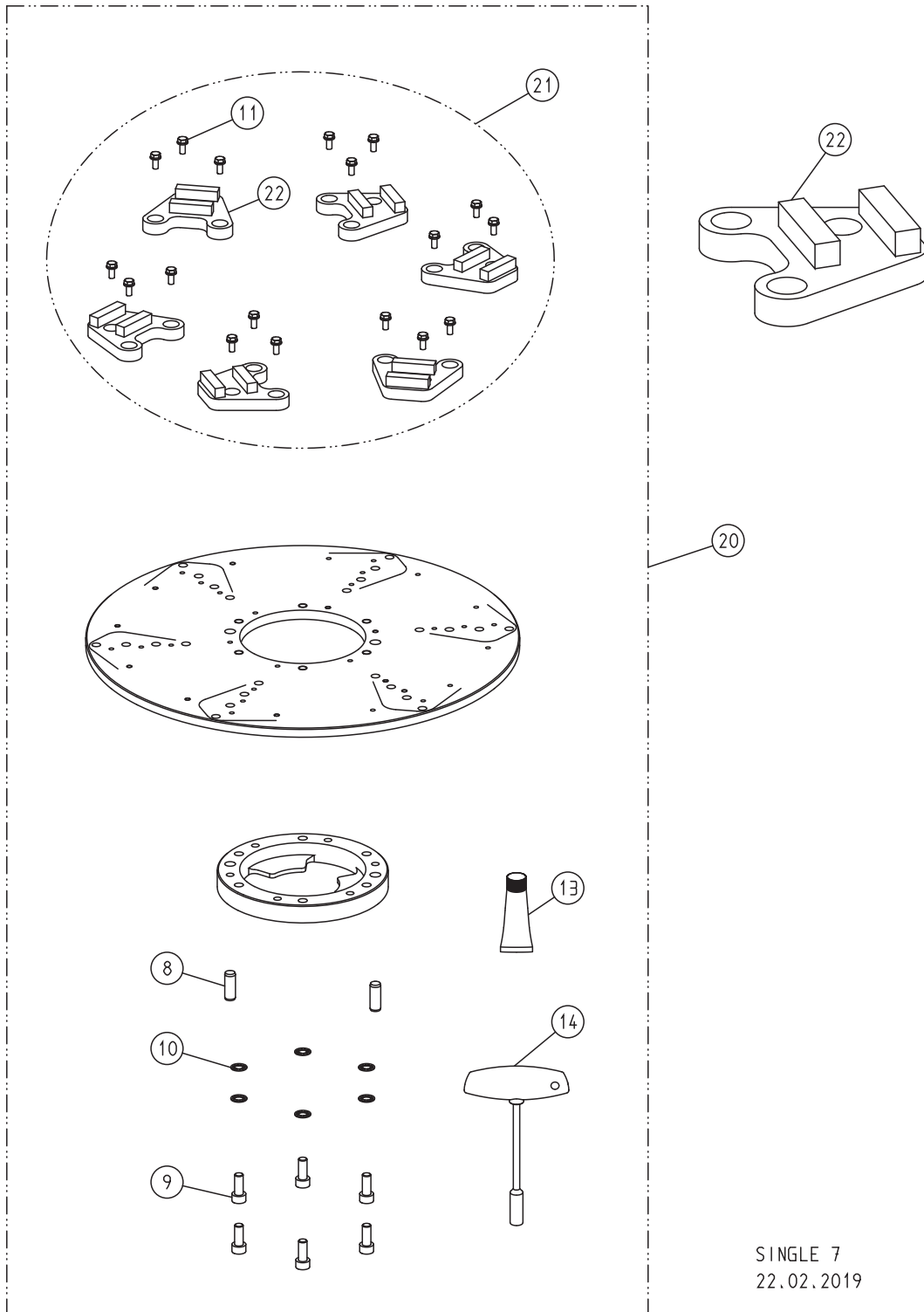

SINGLE 7
22.02.2019

SPARE PARTS SINGLE

Item	Part number	Description
8	7979.0010.028	Parallel pin
9	0912.1008.020	Screw
10	6797.1008.000	Washer
11	6902.0305.012	Screw
13	00.000.32.501	Copper paste
14	000.93.13.052	Hexagonal socket screw wrench 8 x 125 mm
20	850.02.50.100	Diamond sanding disc SINGLE, complete
21	850.02.61.100	Kit for milling disc SINGLE
22	08.900.010.020	Diamond sanding segment, grit 20, red

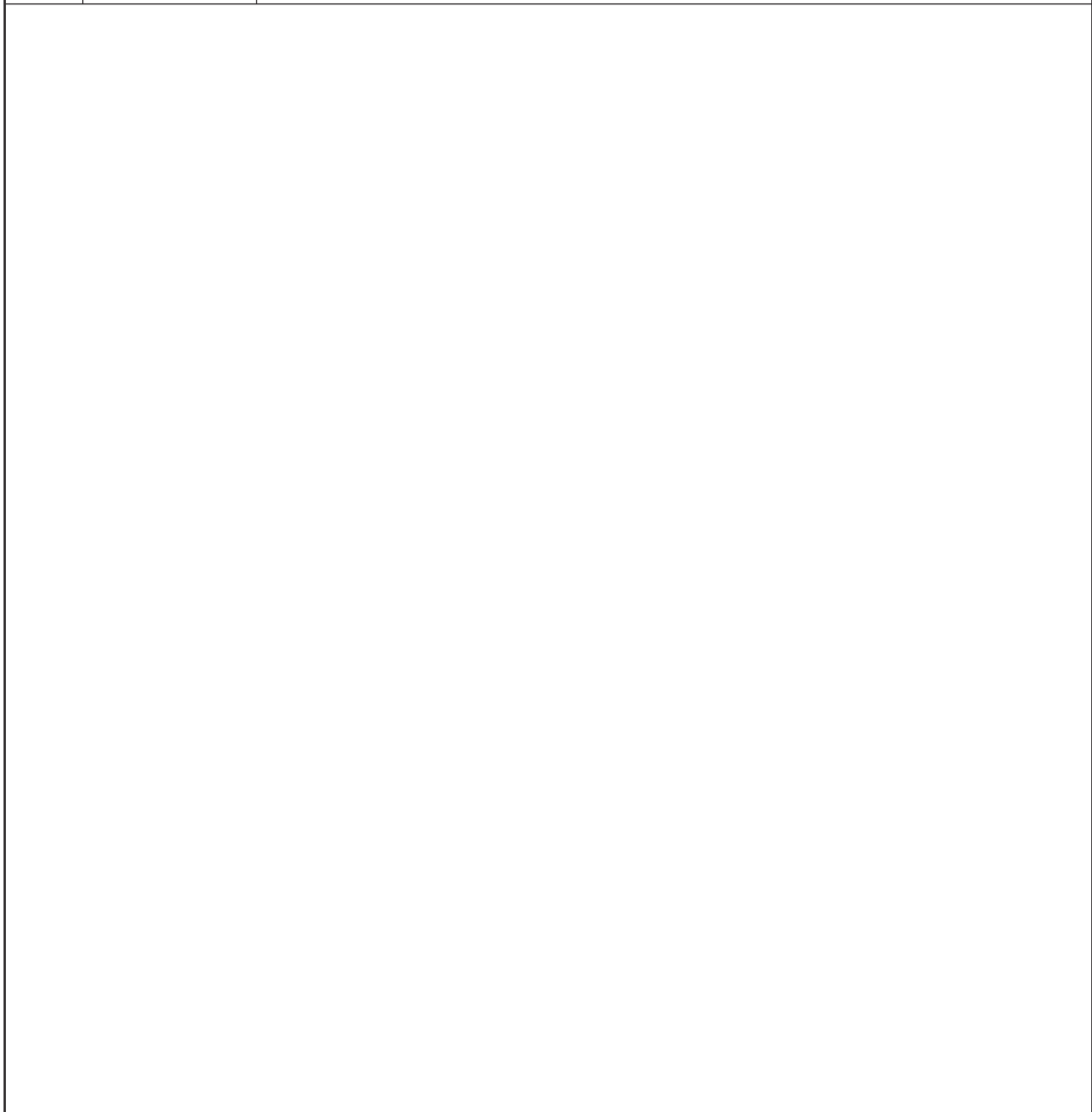

ATTENTION: Please specify in inquiries and spare part orders always the serial numbers of your machines!

SPARE PARTS SINGLE

ATTENTION: Please specify in inquiries and spare part orders always the serial numbers of your machines!

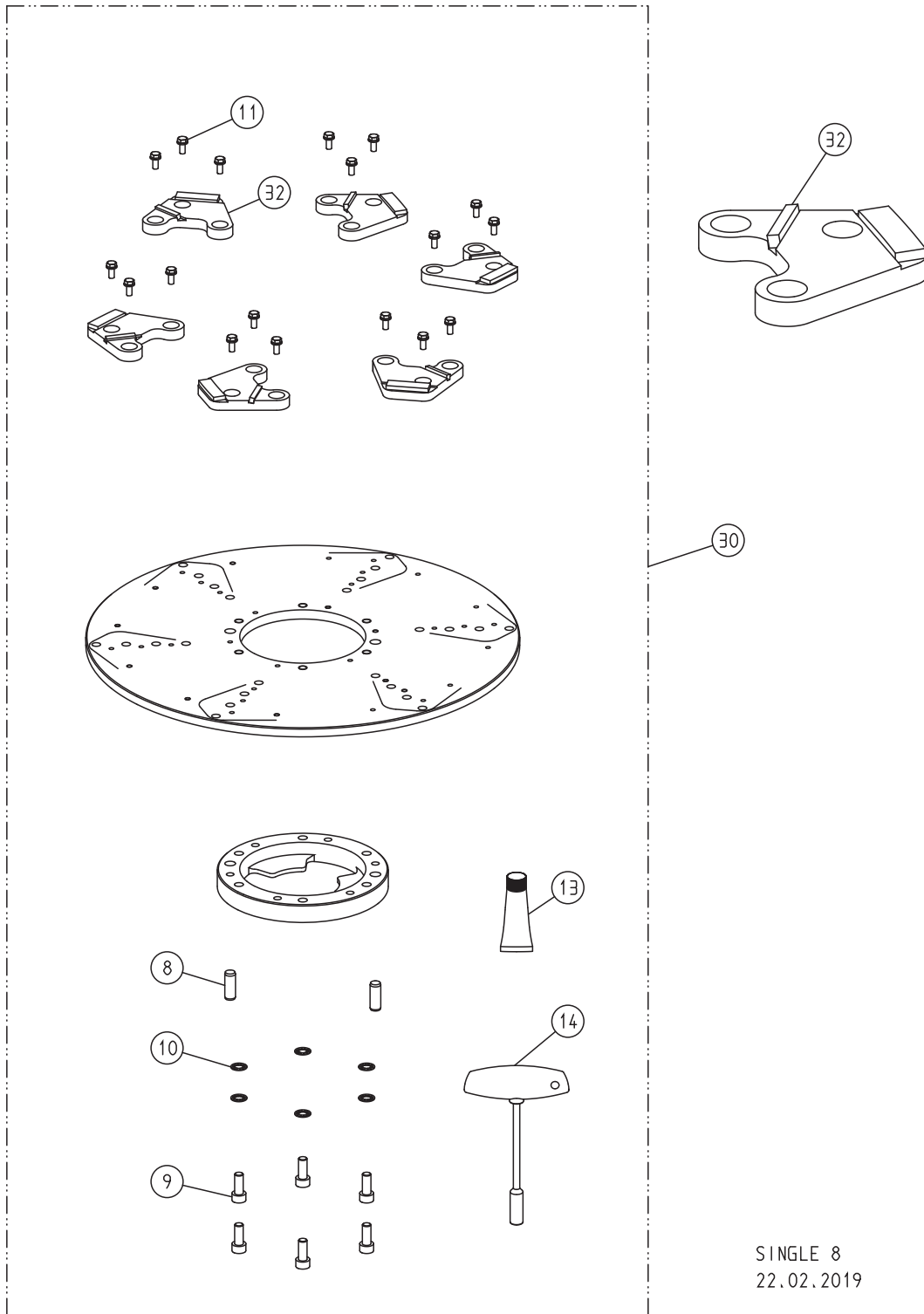

SINGLE 8
22.02.2019

SPARE PARTS SINGLE

Item	Part number	Description
8	7979.0010.028	Parallel pin
9	0912.1008.020	Screw
10	6797.1008.000	Washer
11	6902.0305.012	Screw
13	00.000.32.501	Copper paste
14	000.93.13.052	Hexagonal socket screw wrench 8 x 125 mm
30	850.02.52.100	Scrabber disc SINGLE, wide, green
32	850.06.12.100	Scrabber Green, wide cutting edge

--	--	--

ATTENTION: Please specify in inquiries and spare part orders always the serial numbers of your machines!

SPARE PARTS SINGLE

ATTENTION: Please specify in inquiries and spare part orders always the serial numbers of your machines!

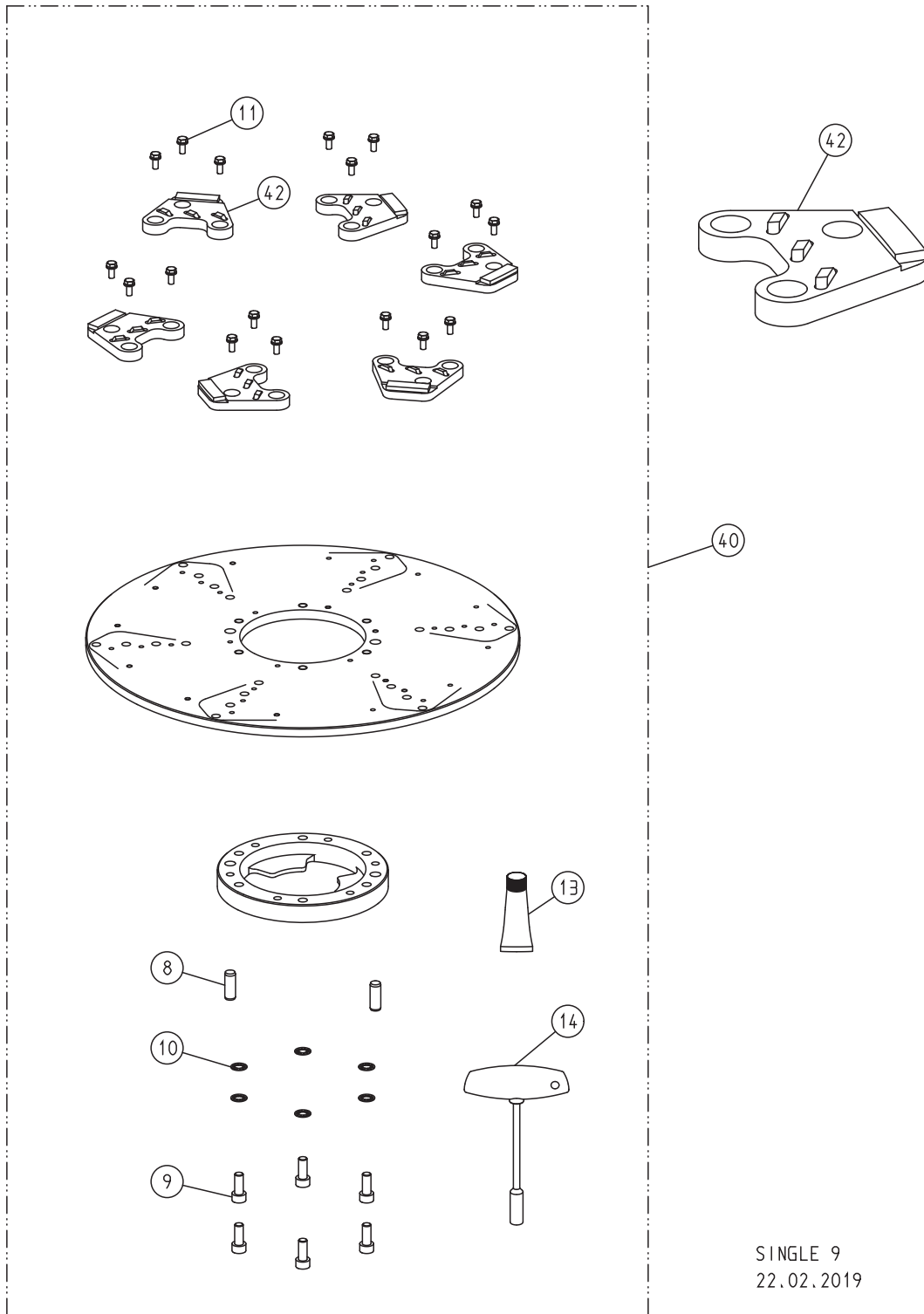

SINGLE 9
22.02.2019

SPARE PARTS SINGLE

Item	Part number	Description
8	7979.0010.028	Parallel pin
9	0912.1008.020	Screw
10	6797.1008.000	Washer
11	6902.0305.012	Screw
13	00.000.32.501	Copper paste
14	000.93.13.052	Hexagonal socket screw wrench 8 x 125 mm
40	850.02.53.100	Scrabber disc SINGLE, narrow, black
42	850.06.13.100	Scrabber Black, 3 narrow cutting edges

ATTENTION: Please specify in inquiries and spare part orders always the serial numbers of your machines!