



English / Englisch

# Spare Parts

for the belt sanding machine

# HUMMEL®

**Lägler**  
www.laegler.com



00.100.20.802 01.06.2020

**ATTENTION!**

In order to receive the correct spare parts from us, please specify in inquiries and spare part orders always the serial numbers of your machines!

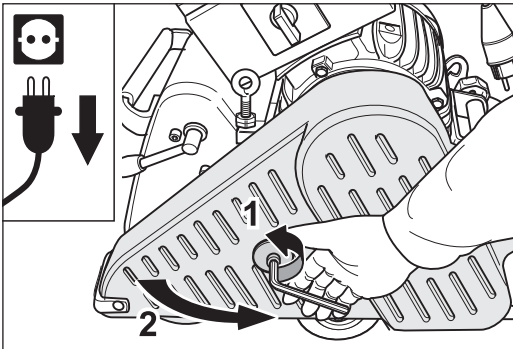

Fig. 1 Pull the power plug out of the socket and open the belt guard.

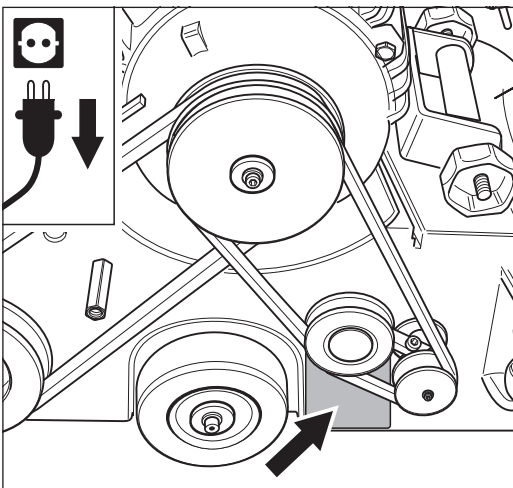

Fig. 2 Machine type plate on machine housing.

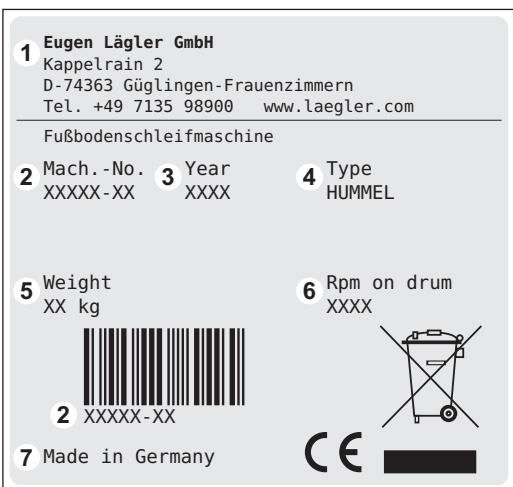

Fig. 3 Data on machine type plate.

**TYPE PLATE ON MACHINE**

In order to be able to read the machine type plate of the HUMMEL®, proceed as follows:

- 1 The machine **must be switched off!**
- 2 **Pull the power plug out of the socket!**
- 3 Open the belt guard (fig. 1)
- 4 The machine type plate is located on the machine housing below the belt tensioner (fig. 2).

The following technical data are specified on the machine type plate (fig. 3):

- 1 Manufacturer
- 2 **Serial number of machine (Mach.-No.)**
- 3 Year of manufacture (Year)
- 4 Machine name (Type)
- 5 Weight of machine in kilogram (Weight)
- 6 Speed of sanding drum in 1/min (Rpm on drum)
- 7 Country of manufacture

- 5 **Close the belt guard (Fig. 4)!**

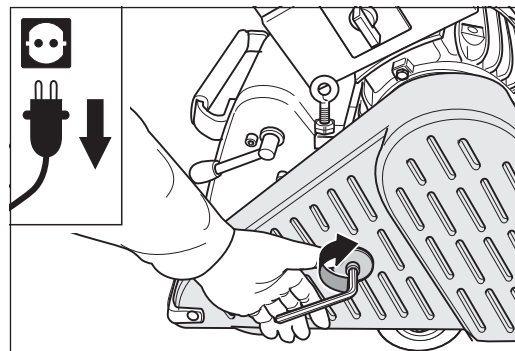

Fig. 4 Close the belt guard.

## TYPE PLATE ON MOTOR

The motor type plate of the HUMMEL® is located on the switch box of motor (Fig. 5).

The following technical data are specified on the motor type plate (Fig. 6):

- 1 Manufacturer
- 2 **Serial number of machine (Mach.-No.)**
- 3 Year of manufacture (Year)
- 4 Motor size (Type)
- 5 Required mains voltage in volt (V)
- 6 Current consumption in ampere (A)
- 7 Motor frequency in CPS (Hz)
- 8 Motor power in kilowatt (KW)
- 9 Motor speed in 1/min (Rpm)
- 10 Power factor cosine phi (cos)
- 11 Insulation class (Insul. Cl.)
- 12 Protection category (Prot. Cat.)
- 13 Type of current
- 14 Country of manufacture

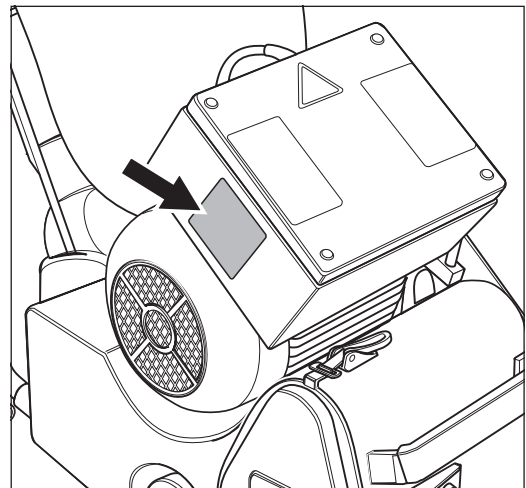

Fig. 5 Motor type plate on switch box.

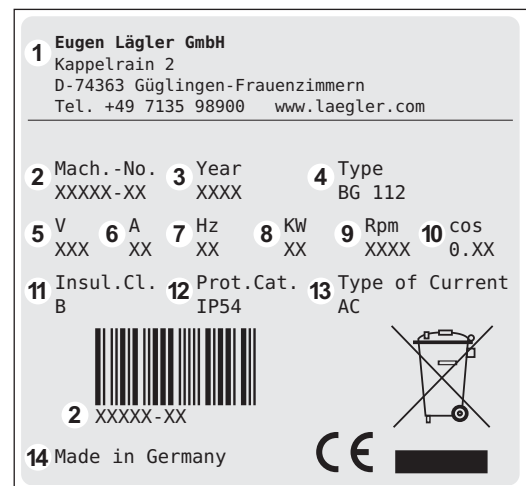
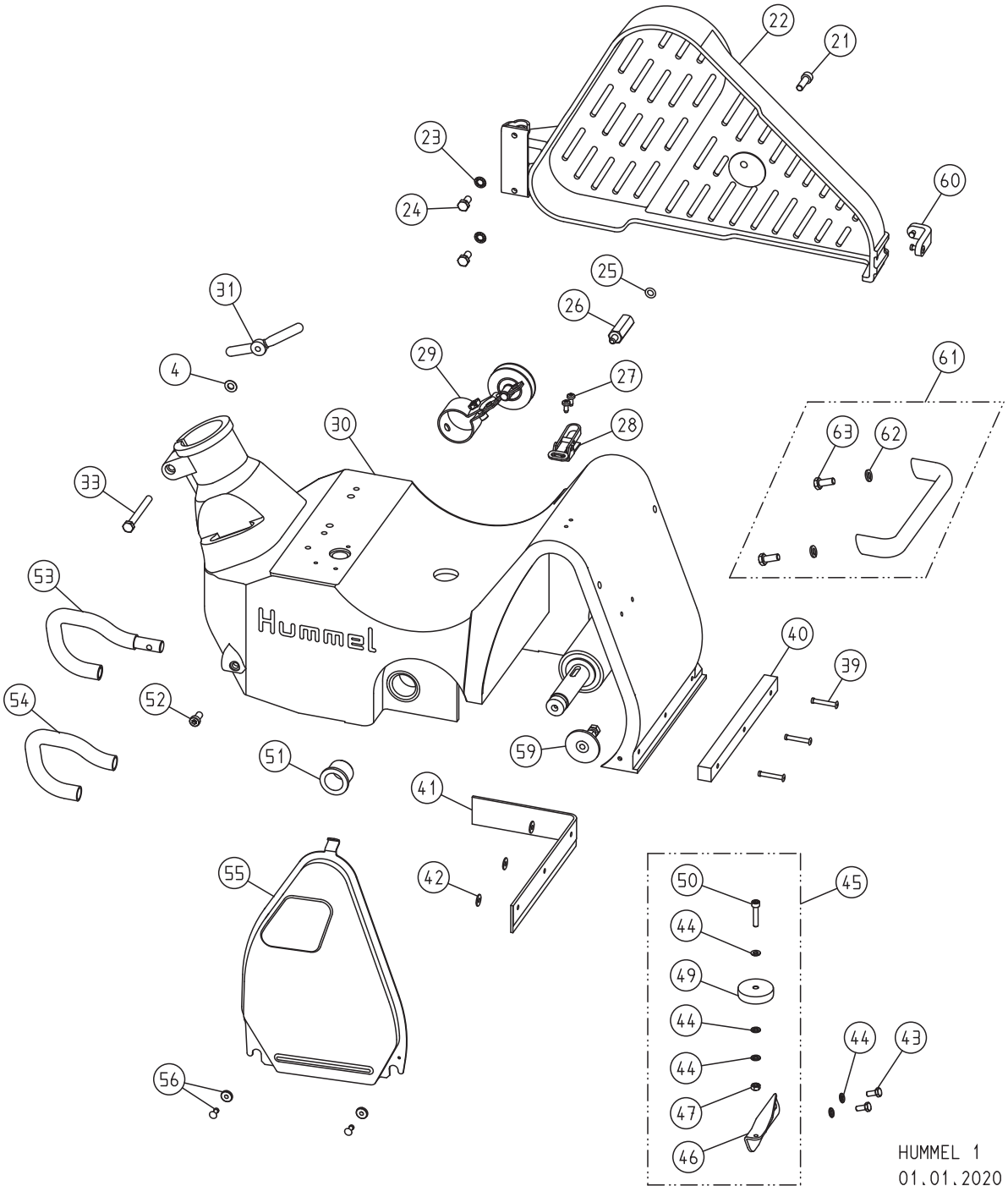

Fig. 6 Data on motor type plate.

SPARE PARTS HUMMEL®

ATTENTION: Please specify in inquiries and spare part orders always the serial numbers of your machines!



HUMMEL 1  
01.01.2020

SPARE PARTS HUMMEL®

Item	Part number	Description
4	0125.1008.000	Washer
21	0912.1008.025	Screw
22	100.50.00.100	Belt guard, complete
23	6797.1008.000	Washer
24	0933.1008.016	Screw
25	000.01.40.001	O-ring
26	100.50.04.105	Screw stud
27	7500.1005.012	Screw
28	100.01.05.105	Cover fastener
29	100.58.00.200	Belt tensioner, complete
30	100.01.00.100	Machine housing
31	000.20.45.081	Wing nut
33	0931.1008.075	Screw
39	7337.1005.033	Rivet
40	100.01.01.100	Bumper felt
41	100.01.02.100	Sealing felt
42	9021.1005.000	Washer
43	0933.1006.014	Screw
44	0125.1006.000	Washer
45	100.60.00.200	Wall-protecting roller with holder
46	100.60.01.100	Holder for wall-protecting roller
47	0934.1006.000	Nut
49	100.60.02.200	Wall-protecting roller
50	0912.1006.030	Screw
51	000.43.10.252	Plastic bushing
52	7984.1008.016	Screw
53	100.44.00.100	Safety guard, complete
54	100.44.01.100	PVC tube
55	100.01.03.100	Side cover
56	100.01.08.200	Collar nut, complete
59	100.01.30.100	Guide roller, complete
60	100.50.05.100	Bumper guard with rivets
61	100.33.01.200	Bracket complete
	100.33.02.100	Grip of bracket (for HUMMEL built till 2019)
62	0127.1008.000	Spring washer
63	0933.1008.020	Screw

ATTENTION: Please specify in inquiries and spare part orders always the serial numbers of your machines!

SPARE PARTS HUMMEL®

ATTENTION: Please specify in inquiries and spare part orders always the serial numbers of your machines!

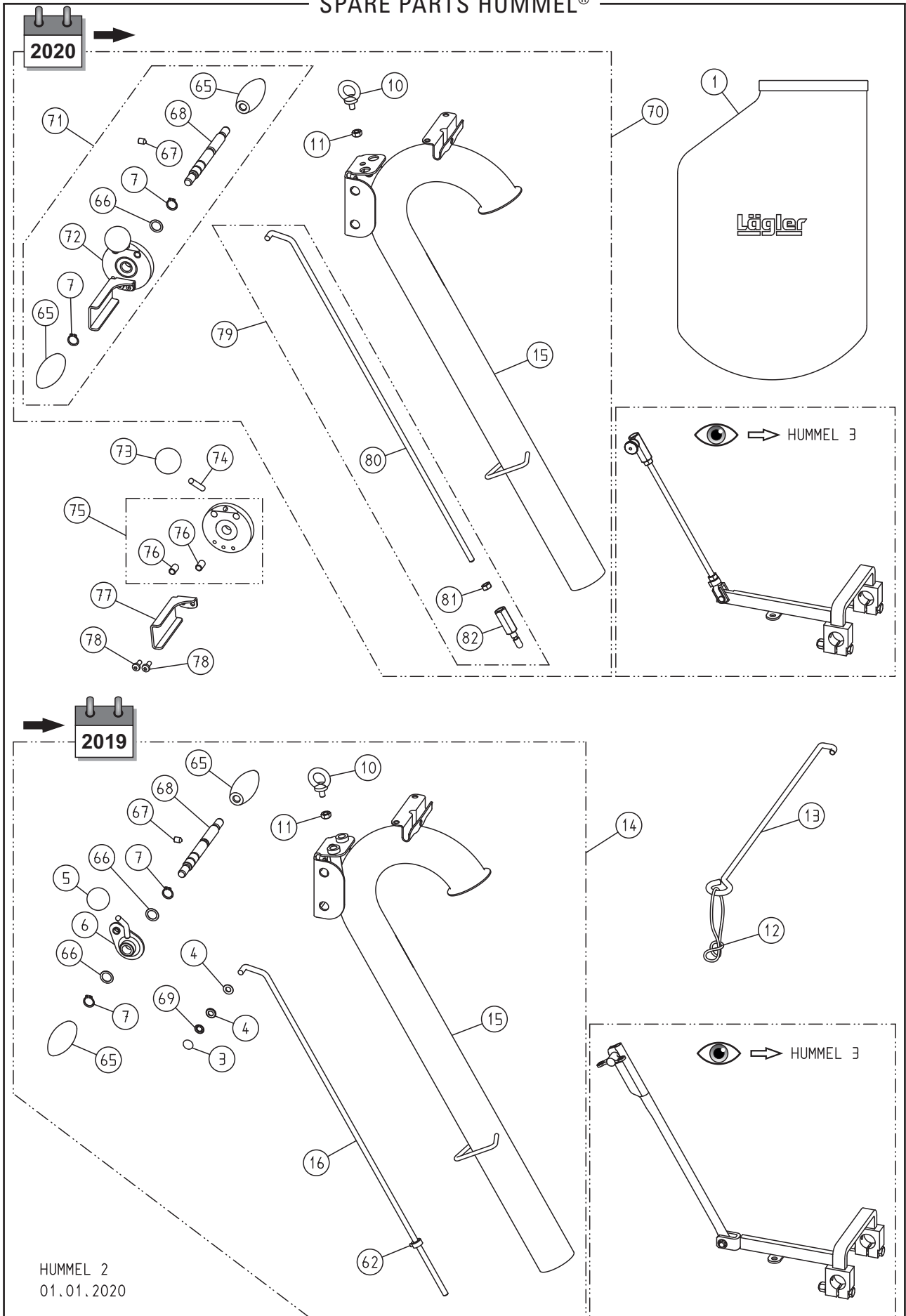

HUMMEL 2  
01.01.2020

SPARE PARTS HUMMEL®

Item	Part number	Description
1	100.00.80.105	Dust bag for HUMMEL, SUPERHUMMEL, ELF
3	000.17.21.081	Fixing cap
4	0125.1008.000	Washer
5	000.20.56.351	Ball knob
6	100.20.18.200	Lever
7	0471.0015.000	Circlip
10	0580.1008.000	Thread eye
11	0980.1008.000	Nut
12	00.000.41.002	Strain relief ring
13	100.20.26.100	Cable support, complete
14	100.20.00.200	Guide tube, complete
	102.20.00.200	Guide tube USA, complete
	100.21.00.200	Guide tube long, complete
15	100.20.01.200	Guide tube
	102.20.01.200	Guide tube USA
16	100.20.24.100	Upper rod, complete
	100.20.90.200	Upper rod HUMMEL/ELF for sinistrals, complete (conversion set, for HUMMEL built till 2019)
62	100.20.23.200	Adjusting ring, complete
65	000.20.31.351	Handle
	000.20.01.001	Handle in wood
66	0988.0015.005	Washer
67	0914.0008.012	Grub screw
68	100.20.17.200	Axle for handle
69	000.17.20.081	Quick-fixing-fastener
70	100.20.00.300	Guide tube, complete (for HUMMEL built 2020 onwards)
	102.20.00.300	Guide tube USA, complete (for HUMMEL built 2020 onwards)
	100.21.00.300	Guide tube long, complete (for HUMMEL built 2020 onwards)
71	100.20.38.100	Conversion kit Paddle (for HUMMEL built till 2019)
72	100.20.40.100	Lowering lever (for HUMMEL built 2020 onwards)
73	000.20.56.401	Ball knob
74	100.20.45.100	Bar ball knob (for HUMMEL built 2020 onwards)
75	100.20.42.100	Disk lowering lever (for HUMMEL built 2020 onwards)
76	000.43.11.081	Plastic bushing
77	100.20.46.100	Plate quick lift (for HUMMEL built 2020 onwards)
78	7985.1006.816	Screw
79	100.20.50.100	Upper rod, complete (for HUMMEL built 2020 onwards)
	100.21.50.100	Upper rod long, complete (for HUMMEL built 2020 onwards)
80	100.20.51.100	Upper rod (for HUMMEL built 2020 onwards)
	100.21.51.100	Upper rod long (for HUMMEL built 2020 onwards)
81	0934.1008.000	Nut
82	100.20.52.100	Setting sleeve (for HUMMEL built 2020 onwards)

ATTENTION: Please specify in inquiries and spare part orders always the serial numbers of your machines!

SPARE PARTS HUMMEL®

ATTENTION: Please specify in inquiries and spare part orders always the serial numbers of your machines!

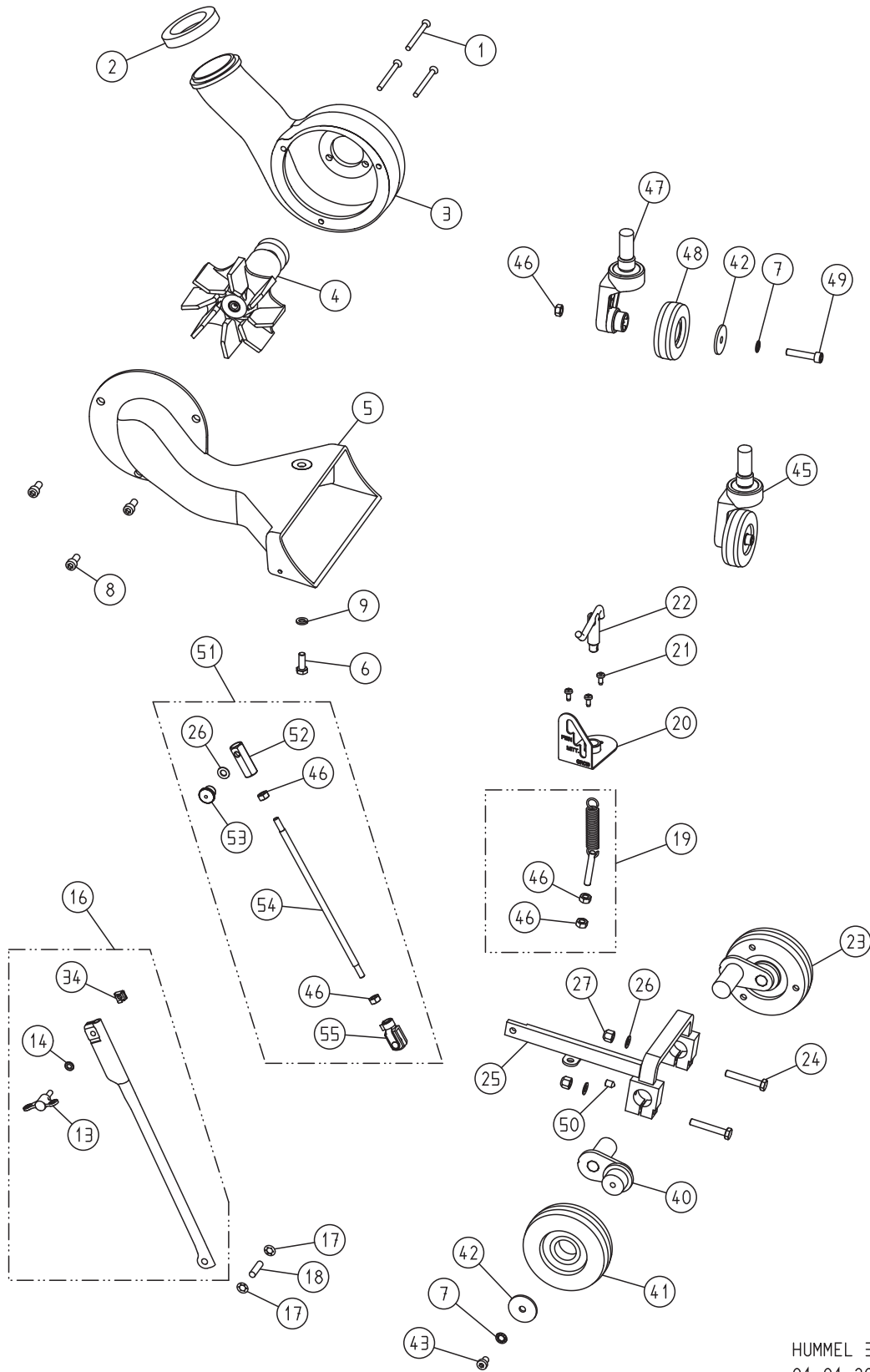

HUMMEL 3  
01.01.2020



SPARE PARTS HUMMEL®

Item	Part number	Description
1	0965.1006.870	Screw
2	100.08.01.200	Sealing ring
3	100.08.00.100	Fan housing
4	100.10.00.200	Fan insert, complete
5	100.14.00.100	Intake duct
6	0933.1008.022	Screw
7	6797.1008.000	Washer
8	0912.1008.018	Screw
9	0127.1008.000	Spring washer
13	000.20.46.062	Wing screw
14	0125.1006.000	Washer
16	100.04.09.100	Lower rod, complete
17	000.17.20.081	Quick-fixing-fastener
18	100.04.01.200	Pivot pin
19	100.04.25.100	Spring with screw, complete
20	100.04.06.200	Notch plate
21	7500.1005.012	Screw
22	100.04.02.100	Spring tensioner, complete
23	100.05.00.200	Lateral wheel, complete
24	0931.1008.050	Screw
25	100.04.50.100	Lifting fixture (for HUMMEL built 2020 onwards)
	100.04.00.100	Lifting fixture
26	0125.1008.000	Washer
27	6330.1008.000	Nut
34	000.50.12.061	Nut
40	100.05.04.200	Wheel arm
41	100.05.29.100	Lateral wheel (from year of manufacture June 1999)
42	000.10.10.085	Washer
43	7984.1008.012	Screw
45	100.18.00.300	Rear wheel, complete
46	0934.1008.000	Nut
47	100.18.18.300	Tail axle housing, complete
48	100.18.29.105	Rear wheel (from year of manufacture 2002)
	100.18.09.200	Rear wheel (up to year of manufacture 2001)
49	0912.1008.040	Screw
50	0914.0008.012	Grub screw
51	100.04.58.100	Lower rod, complete (for HUMMEL built 2020 onwards)
52	100.04.56.100	Snap piece (for HUMMEL built 2020 onwards)
53	000.20.15.004	Stop bolt (for HUMMEL built 2020 onwards)
54	100.04.55.100	Lower rod (for HUMMEL built 2020 onwards)
55	000.25.11.901	Fork joint (for HUMMEL built 2020 onwards)

ATTENTION: Please specify in inquiries and spare part orders always the serial numbers of your machines!

SPARE PARTS HUMMEL®

ATTENTION: Please specify in inquiries and spare part orders always the serial numbers of your machines!

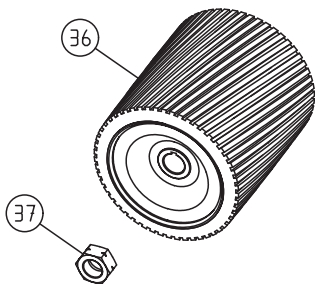
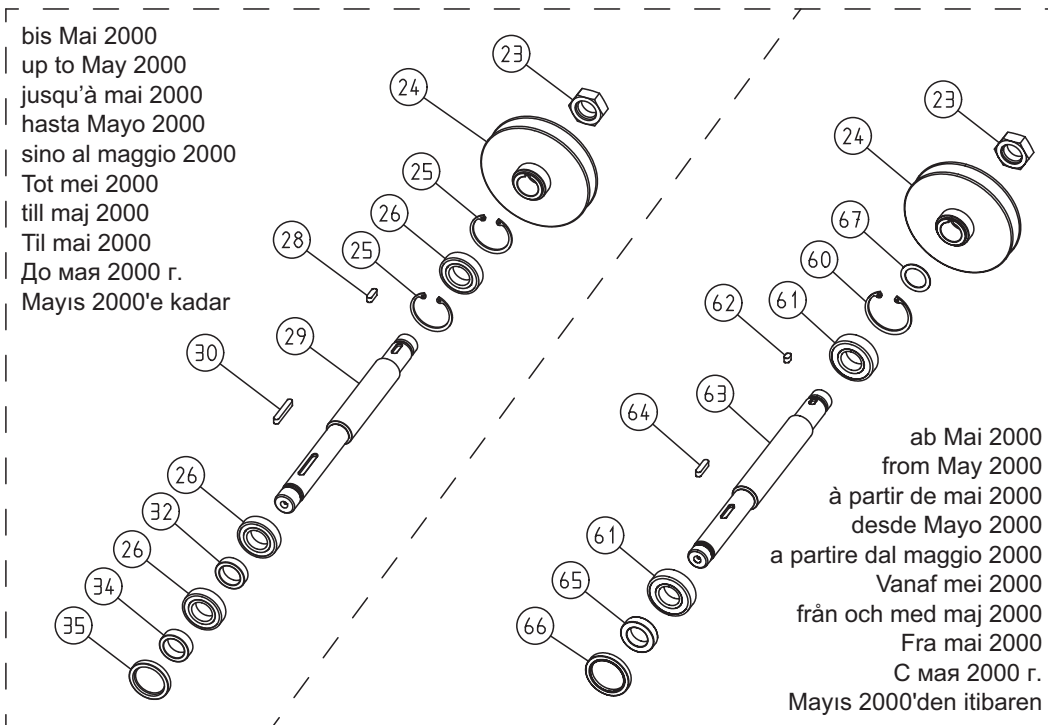
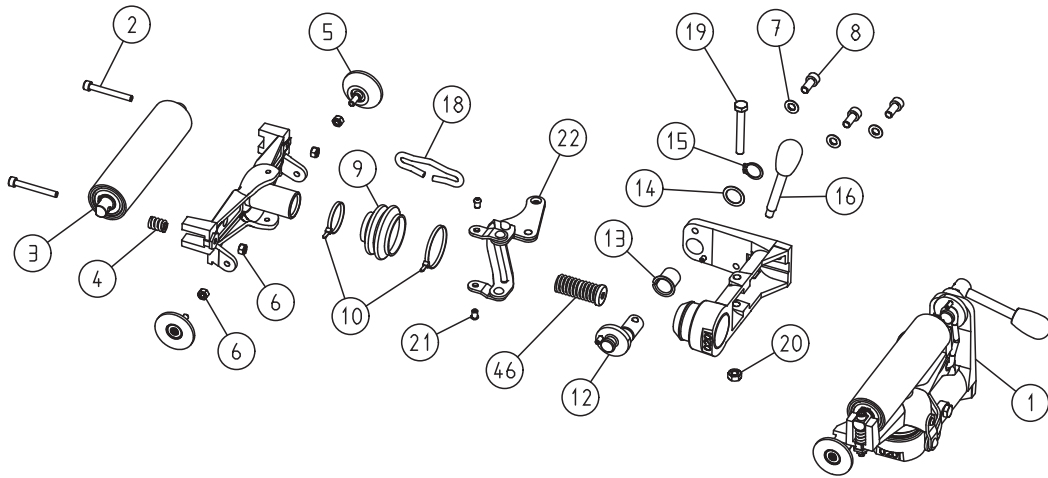

HUMMEL 4  
01.06.2013

SPARE PARTS HUMMEL®

Item	Part number	Description
1	100.45.00.100	Drive unit, complete
2	0912.1006.050	Screw
3	100.45.12.105	Tensioning roller
4	000.31.13.021	Pressure spring
5	100.45.01.105	Guide roller
6	0980.1006.000	Nut
7	0125.1008.000	Washer
8	0912.1008.018	Screw
9	100.45.81.105	Collar
10	000.61.10.363	Cable tie
12	100.45.20.100	Crank
13	100.45.24.105	Bearing bush
14	0988.0018.005	Washer
15	0471.0018.000	Circlip
16	000.20.32.104	Operating lever
18	100.45.17.100	Clip
19	0931.1008.060	Screw
20	0980.1008.000	Nut
21	100.45.61.205	Screw
22	100.45.37.100	Double arm, complete
23	100.02.05.100	Nut, right-hand thread
24	100.36.00.100	V-belt pulley
25	0472.0047.000	Circlip
26	6005.0025.205	Ball bearing
28	6885.0606.018	Parallel key
29	100.02.01.100	Sanding shaft
30	6885.0606.040	Parallel key
32	100.02.04.105	Spacer ring
34	100.02.03.105	Slide ring
35	000.11.35.102	Shaft seal
36	120.40.00.100	Sanding drum HUMMEL
	120.41.00.100	Sanding drum HUMMEL, hard rubber cover
37	100.02.06.100	Nut, left-hand thread
46	100.45.45.100	Pressure spring
60	0472.0052.000	Circlip
61	6205.0025.205	Ball bearing
62	6885.0606.010	Parallel key
63	100.02.01.200	Sanding shaft
64	6885.0606.025	Parallel key
65	100.02.03.200	Spacer ring
66	000.11.40.102	Shaft seal
67	0988.0025.010	Washer

ATTENTION: Please specify in inquiries and spare part orders always the serial numbers of your machines!

SPARE PARTS HUMMEL®

ATTENTION: Please specify in inquiries and spare part orders always the serial numbers of your machines!

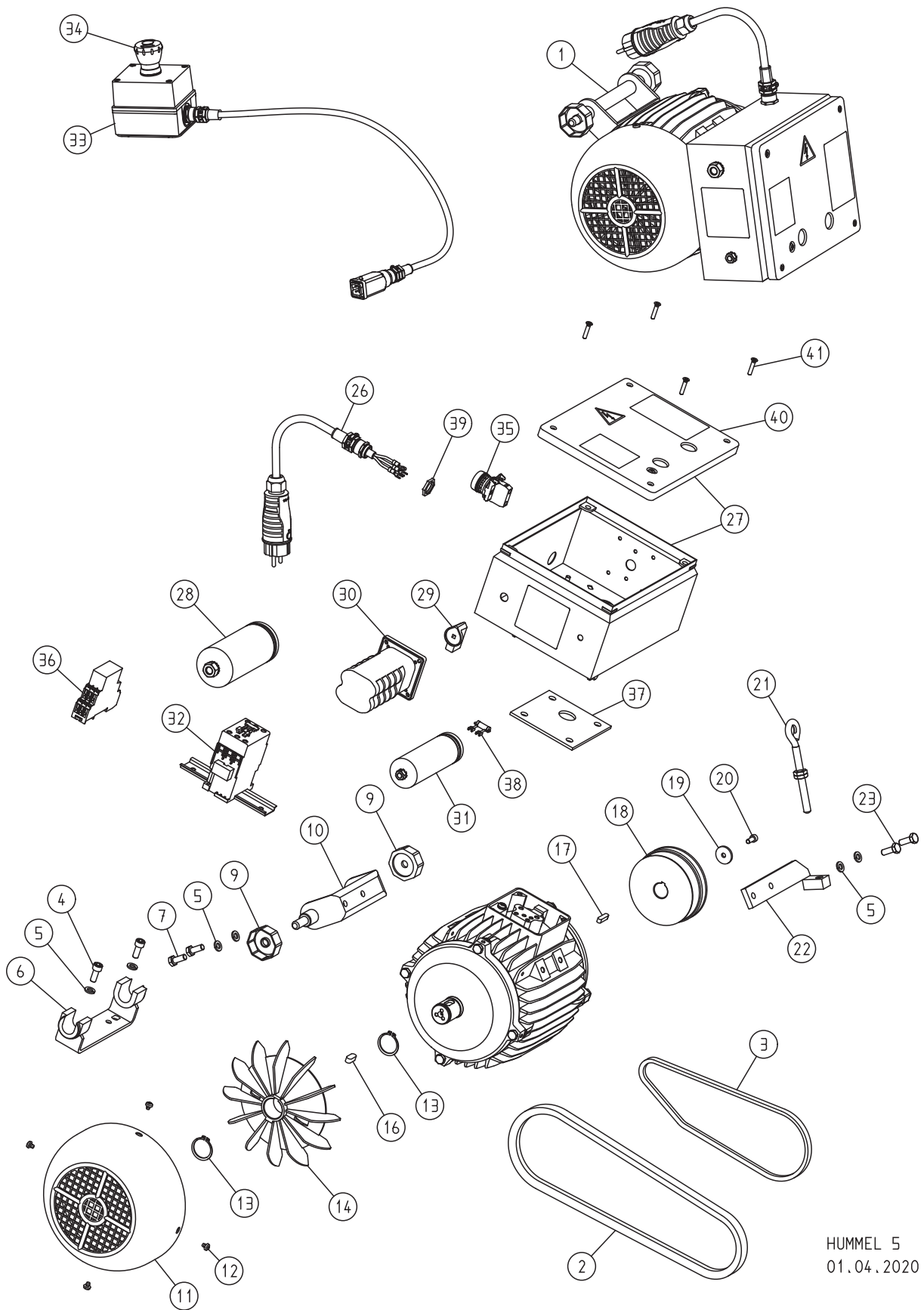

HUMMEL 5  
01.04.2020

Item	Part number	Description
1	100.65.00.100	Motor, 230 V / 50 CPS / 2.2 kW
	101.65.00.100	Motor, 230 V / 60 CPS / 2.2 kW
	102.65.00.100	Motor, 220 V / 60 CPS / 2.9 kW, USA
	105.65.00.100	Motor, 400 V / 50 CPS / 4.0 kW, three-phase current
2	000.70.17.092	V-belt
3	000.70.10.067	V-belt
4	0912.1008.020	Screw
5	0127.1008.000	Spring washer
6	100.65.29.200	Motor bearing bracket
7	0933.1008.020	Screw
9	100.65.30.100	Motor nut
10	100.65.25.100	Motor mounting
11	100.65.09.100	Fan cover
12	7500.1005.006	Screw
13	0471.0030.000	Circlip
14	100.65.08.105	Fan wheel
16	6885.0807.020	Parallel key
17	6885.0606.025	Parallel key
18	100.65.06.100	Motor pulley
19	000.10.10.061	Washer
20	0912.1006.014	Screw
21	100.65.80.205	Eye bolt
22	100.65.35.100	Motor tensioner
23	0933.1008.022	Screw
26	100.65.75.100	Motor cable 3 x 2.5 mm <sup>2</sup> (from year of manufacture 2008)
	000.65.43.251	Motor cable 3 x 2.5 mm <sup>2</sup> (up to year of manufacture 2007)
	102.65.75.100	Motor cable 3 x 2.5 mm <sup>2</sup> , USA (from year of manufacture 2008)
	000.65.43.257	Motor cable 3 x 2.5 mm <sup>2</sup> , USA (up to year of manufacture 2007)
	105.65.75.100	Motor cable 5 x 1.5 mm <sup>2</sup> for three-phase AC motor (from year of manufacture 2008)
	000.65.45.151	Motor cable 5 x 1.5 mm <sup>2</sup> for three-phase AC motor (up to year of manufacture 2007)
27	100.65.40.200	Switch box for 230 V / 50 CPS
	102.65.40.200	Switch box for 220-230 V / 60 CPS + three-phase current
28	000.65.10.041	Running capacitor 40 µF
29	000.65.62.211	Switch button
30	000.65.60.253	Switch
	000.65.60.401	Switch for three-phase AC motor
31	000.65.10.061	Starting capacitor 60 µF
	000.65.10.131	Starting capacitor 130 µF, USA
32	000.65.20.035	Contacteur
	000.65.20.032	Contacteur complete for three-phase AC motor
33	102.65.60.200	Emergency switch USA, complete
34	000.65.62.221	Red button for emergency switch USA
35	000.65.25.020	Lamp red for three-phase AC motor
36	000.65.20.220	Relay for three-phase AC motor
37	100.65.14.105	Sealing plate
38	000.65.12.091	Discharging resistor
39	000.68.60.207	Nut (from year of manufacture 2008)
	000.68.60.163	Nut (up to year of manufacture 2007)
40	100.65.47.200	Cover with seal
41	7500.1005.825	Screw

ATTENTION: Please specify in inquiries and spare part orders always the serial numbers of your machines!

SPARE PARTS HUMMEL®

ATTENTION: Please specify in inquiries and spare part orders always the serial numbers of your machines!

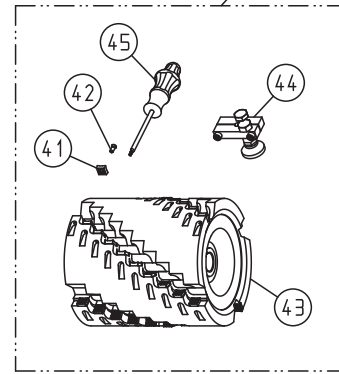
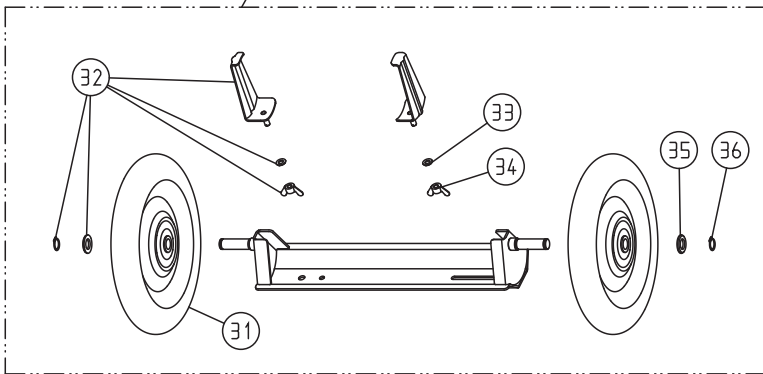
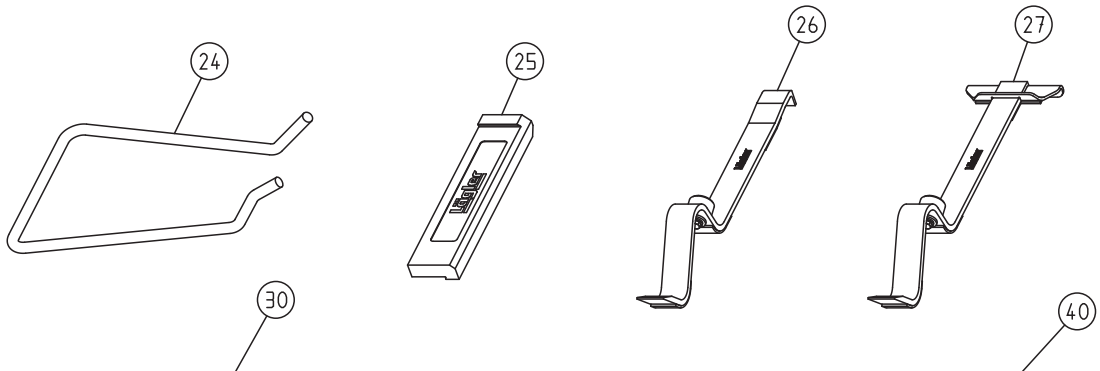
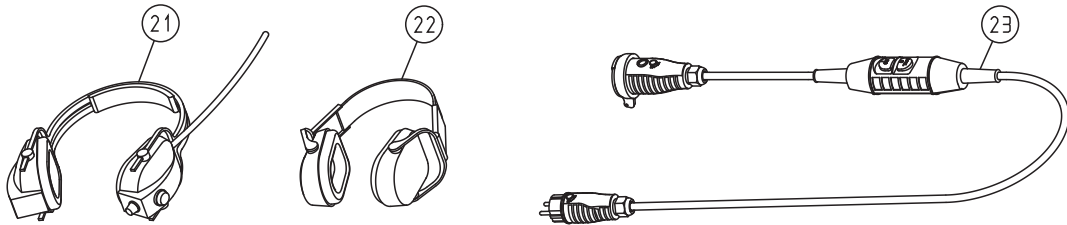
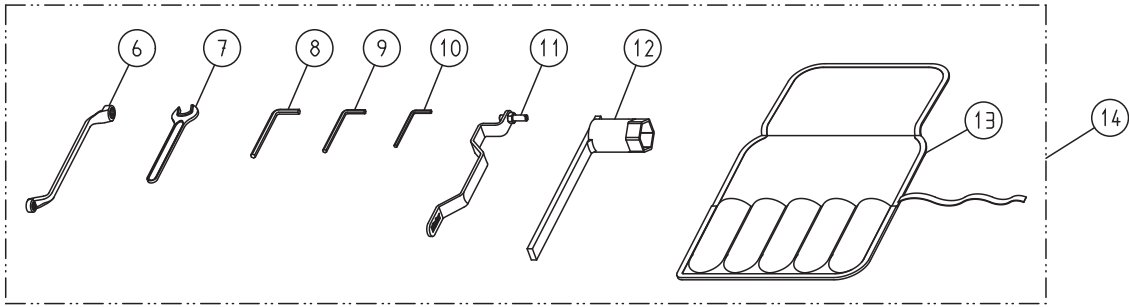
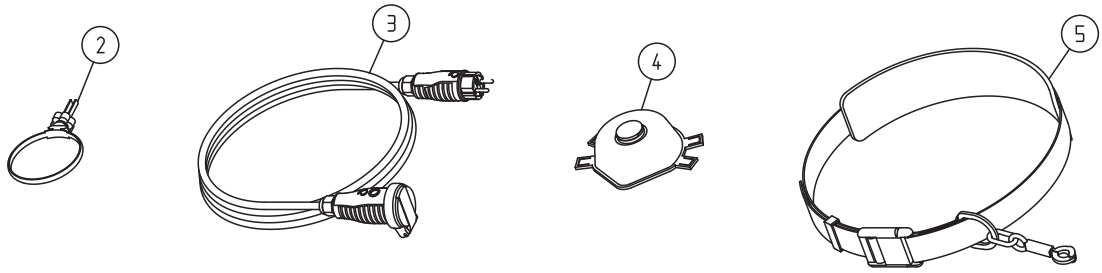

HUMMEL 6  
01.01.2020

SPARE PARTS HUMMEL®

Item	Part number	Description
2	000.01.40.110	MultiClip
3	000.65.53.251	Extension cable 3 x 2.5 mm <sup>2</sup> , 10 m long
	000.65.53.252	Extension cable 3 x 2.5 mm <sup>2</sup> , 20 m long
	000.65.55.151	Extension cable 5 x 1.5 mm <sup>2</sup> , 10 m long, for three-phase AC motor
4	000.01.20.010	Respiratory protection mask P3
5	000.01.50.010	Safety belt
6	000.95.21.103	Closed mouth wrench 10/13 mm
7	000.95.11.171	Open mouth wrench 17 mm
8	000.93.11.061	Hexagonal socket screw wrench 6 mm
9	000.93.11.051	Hexagonal socket screw wrench 5 mm
10	000.93.11.041	Hexagonal socket screw wrench 4 mm
11	100.00.50.100	Setting fixture
12	100.00.45.105	Box wrench
13	000.01.30.011	Tool bag, empty
14	100.98.00.100	Tool bag, complete
21	000.01.10.011	Foldable earmuff type MUSIMUFF with FM radio
22	000.01.10.021	Foldable earmuff type POCKET
23	000.01.65.020	Safety switch PRCD-S (for German mains supply)
24	100.00.55.100	Carrying handle HUMMEL
25	701.10.00.100	Impact tool
26	702.00.00.200	Parquet layer tool ZUGEISEN, small
27	703.00.00.200	Parquet layer tool ZUGEISEN, broad
30	720.00.00.200	Trolley TRANSCART, complete
31	720.05.00.205	Wheel TRANSCART
32	720.10.00.200	Accessories TRANSCART
33	0125.1008.000	Washer
34	0315.1008.000	Wing nut
35	0125.1016.000	Washer
36	0471.0017.000	Circlip
40	000.10.42.240	Milling drum 200 mm width, complete with accessories
41	900.02.45.105	Carbide indexable insert (10 pieces per package)
42	900.02.47.105	Screw for indexable insert
43	000.10.42.241	Milling drum with indexable inserts HUMMEL
44	000.10.42.243	Cutting depth adjustment, complete
45	000.91.30.151	Torx screwdriver T15

ATTENTION: Please specify in inquiries and spare part orders always the serial numbers of your machines!

SPARE PARTS HUMMEL®

ATTENTION: Please specify in inquiries and spare part orders always the serial numbers of your machines!

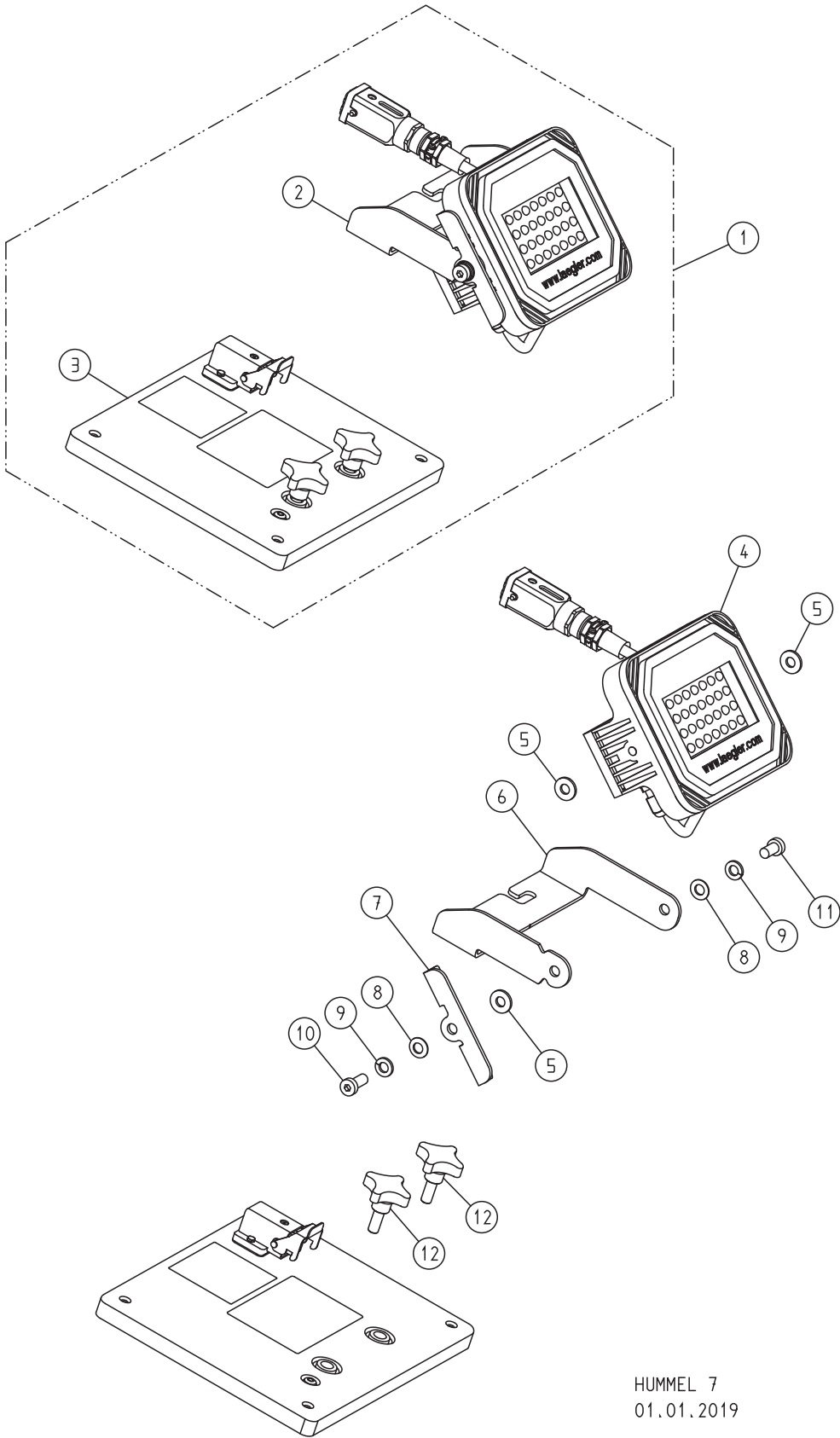

HUMMEL 7  
01.01.2019



SPARE PARTS HUMMEL®

Item	Part number	Description
1	100.63.00.100	Upgrade kit HUMMEL LED light year of build 1990 onwards. The installation of the LED light must be carried out by a qualified electrician!
	100.63.00.200	Upgrade kit HUMMEL LED light built 2020 onwards. The installation of the LED light must be carried out by a qualified electrician!
2	100.63.01.100	LED work light, complete
3	100.63.47.100	Cover of switch box, for LED light
4	100.63.03.100	LED work light
5	000.10.10.089	Washer
6	100.63.12.100	Light holder
7	100.63.13.100	Swivel stopper
8	0125.1008.000	Washer
9	0127.1008.000	Spring washer
10	7984.1008.020	Screw
11	7984.1008.016	Screw
12	000.20.20.085	Cross formed screw



ATTENTION: Please specify in inquiries and spare part orders always the serial numbers of your machines!